

UC3846

SMPS Controller

Features

- Automatic Feed Forward Compensation
- Programmable Pulse by Pulse Current Limiting
- Automatic Symmetry Correction in Push-Pull Configuration
- Enhanced Load Response Characteristics
- Parallel Operation Capability for Modulator Power Systems
- Differential Current Sense Amplifier with Common Mode Range
- Double Pulse Suppression
- 200mA Totem-Pole Outputs
- $\pm 2\%$ Band gap Reference
- Under-Voltage Lockout
- Soft-Start Capability
- Shutdown Terminal
- 500KHz Operation

Description

The UC3846 control IC provides all of the necessary features to implement fixed frequency, current mode control schemes while maintaining a minimum external parts count. The superior performance of this technique can be measured in improved line regulation, enhanced load response characteristics, and a simpler, easier-to-design control loop. Topological advantages include inherent pulse-by-pulse current limiting capability, automatic symmetry correction for push-pull converters, and the ability to parallel "power module" while maintaining equal current sharing. Protection circuitry includes built-in-under-voltage lockout and programmable current limit in addition to soft-start capability. A shutdown function is also available which can initiate either a complete shutdown with automatic restart or latch the supply off. Other features include fully latched operation, double pulse suppression, deadtime adjust capability, and $\pm 2\%$ trimmed bandgap reference. The UC3846 features low outputs in the OFF state.



Internal Block Diagram

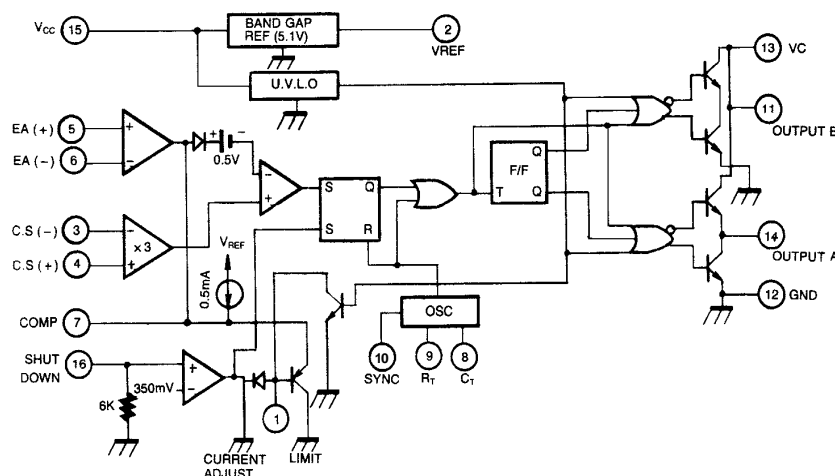

Absolute Maximum Ratings

Parameter	Symbol	Value	Unit
Supply Voltage	V _{CC}	40	V
Collector Supply Voltage	V _C	40	V
Output Current, Sink or Source (Peak)	I _O	500	mA
Reference Output Current	I _{REF}	30	mA
Soft Start Sink Current	I _{SINK(S.S)}	50	mA
Sync Output Current	I _{SYNC}	5	mA
Error Amplifier Output Current	I _{O(E.A)}	5	mA
Oscillator Changing Current	I _{CHG(OSC)}	5	mA
Power Dissipation (T _A = 25°C)	P _D	1000	mW
Operating Temperature	T _{OPR}	0 ~ +70	°C
Storage Temperature	T _{STG}	-65 ~ +150	°C
Lead Temperature (Soldering, 10sec)	T _{LEAD}	+300	°C

Electrical Characteristics

(V_{CC}=15V, T_A=0°C to +70°C, unless otherwise specified)

Parameter	Symbol	Conditions	Min.	Typ.	Max.	Unit
REFERENCE SECTION						
Reference Output Voltage	V _{REF}	T _J = 25°C, I _{REF} = 1mA	5.00	5.10	5.20	V
Line Regulation	ΔV _{REF}	V _{CC} = 8 to 40V	-	5	20	mV
Load Regulation	ΔV _{REF}	I _{REF} 1 to 10mA	-	3	15	mV
Temperature Stability(Note 6)	ST _T	-	-	0.4	1.0	mV/°C
Output Voltage Range (Note 6)	V _{REF}	Line, Load, Temp	4.95	-	5.25	V
Short Circuit Output Current	I _{SC}	V _{REF} = 0V	-10	-45	-	mA
Output Noise Voltage(Note 6)	V _{NO}	f = 10Hz to 10KHz, T _J = 25°C	-	100	-	uV
Long-Term Stability(Note 6)	ST	T _J = 125°C, 1KHz	2	5	8	mV

Electrical Characteristics

($V_{CC} = 15V, T_A = 0^\circ C$ to $+70^\circ C$, unless otherwise specified)

Parameter	Symbol	Conditions	Min.	Typ.	Max.	Unit
OSCILLATOR SECTION (Note 2)						
Initial Accuracy	ACCUR	$T_J = 25^\circ C$	39	43	47	KHz
Frequency Change with Voltage	$\Delta f/\Delta V_{CC}$	$V_{CC} = 8$ to $40V$	-	1	2	%
Frequency Change with Temperature (Note 6)	$\Delta f/\Delta T$	-	-	1	-	%
Sync Output High Level	$V_{OH}(SYNC)$	-	3.9	4.35	-	V
Sync Output Low Level	$V_{OL}(SYNC)$	-	-	2.3	2.5	V
Sync Input High Level	$V_{IH}(SYNC)$	$V_8 = 0V$	3.9	-	-	V
Sync Input Low Level	$V_{IL}(SYNC)$	$V_8 = 0V$	-	-	2.5	V
Sync Input Current	$I_I(SYNC)$	Sync Voltage = $3.9V, V_8 = 0V$	-	1.3	1.5	mA
ERROR AMPLIFIER SECTION						
Input Offset Voltage	V_{IO}	-	-	0.5	5	mV
Input Bias Current	I_{BIAS}	-	-	-0.6	-1	μA
Input Offset Current	I_{IO}	-	-	40	250	μA
Common-Mode Range	V_{CM}	$V_{CC} = 8$ to $40V$	0	-	V_{CC2}	V
Open Loop Voltage Gain	G_{VO}	$V_O = 1.2$ to $3V, V_{CM} = 2V$	80	105	-	dB
Unity Gain Bandwidth (Note 6)	BW	$T_J = 25^\circ C$	0.7	1.0	-	MHz
Common Mode Rejection Ratio	CMRR	$V_{CM} = 0$ to $38V, V_{CC} = 40V$	75	100	-	dB
Power Supply Rejection Ratio	PSRR	$V_{CC} = 8$ to $40V$	80	105	-	dB
Output Sink Current	I_{SINK}	$V_{IO} = -15mV$ to $5V, V_7 = 2.5V$	2	6	-	mA
Output Source Current	I_{SOURCE}	$R_L = 15K\Omega$	-0.4	-0.5	-	mA
High Output Voltage	V_{OH}	$R_L = 15K\Omega$	4.3	4.6	-	V
Low Output Voltage	V_{OL}	-	-	0.7	1	V
CURRENT SENSE AMPLIFIER SECTION						
Amplifier Gain (Note 1, 3)	G_V	$V_3 = 0V, Pin 1$ open	2.5	2.75	3.0	V
Maximum Differential Input Signal ($V_4 - V_3$) (Note 1)	$V_{I(DIFF,MAX)}$	$R_L = 15K\Omega, Pin 1$ open	1.1	1.2	-	V
Input Offset Voltage (Note 1)	V_{IO}	$V_1 = 0.5V, Pin 1$ open	-	5	25	mV
Common Mode Rejection Ratio	CMRR	$V_{CM} = 1$ to $12V$	60	83	-	dB
Power Supply Rejection Ratio	PSRR	$V_{CC} = 8$ to $40V$	60	84	-	dB
Input Bias Current (Note 1)	I_{BIAS}	$V_1 = 0.5V, Pin 7$ open	-	-2.5	-10	μA
Input Offset Current (Note 1)	I_{IO}	$V_1 = 0.5V, Pin 7$ open	-	0.08	1	μA
Delay to Outputs (Note 6)	t_D	$T_J = 25^\circ C$	-	200	500	ns

Electrical Characteristics

(V_{CC}=15V, T_A=0°C to +70°C, unless otherwise specified)

Parameter	Symbol	Conditions	Min.	Typ.	Max.	Unit
CURRENT LIMIT ADJUST SECTION						
Current Limit Offset Voltage (Note 1)	V _{IO(C.L)}	V ₃ = 0V V ₄ = 0V, Pin 7 open	0.45	0.5	0.55	V
Input Bias Current	I _{BIAS}	V ₅ = V _{REF} , V ₆ = 0V	-	- 10	- 30	uA
SHUTDOWN TERMINAL SECTION						
Threshold Voltage	V _{TH}	-	250	350	400	mV
Input Voltage Range	V _I	-	0	-	V _{CC}	V
Minimum Latching Current (Note 4)	I(LATCH,MIN)	-	3.0	1.5	-	mA
Maximum Non-Latching Current (Note 5)	I(NONLATCH,MAX)	-	-	1.5	0.8	mA
UNDER-VOLTAGE LOCKOUT SECTION						
Start Threshold	V _{TH(ST)}	-	7	7.7	8.4	V
Threshold Hysteresis	V _{HYS}	-	0.45	0.75	1.05	V
OUTPUT SECTION						
Collector-Emitter Voltage	V _{CEO}	-	40	-	-	V
Collector Leakage Current	I _{LEAK}	V _C = 40V	-	-	200	uA
Low Output Voltage 1	V _{OL 1}	I _{SINK} = 20mA	-	0.1	0.4	V
Low Output Voltage 2	V _{OL 2}	I _{SINK} = 100mA	-	0.4	2.1	V
High Output Voltage 1	V _{OH 1}	I _{SOURCE} = 20mA	13	13.5	-	V
High Output Voltage 2	V _{OH 2}	I _{SOURCE} = 100mA	12	13.5	-	V
Rise Time (Note 6)	t _R	C _L = 1nF, T _J = 25°C	-	50	300	us
Fall Time (Note 6)	t _F	C _L = 1nF, T _J = 25°C	-	50	300	us
TOTAL STANDBY CURRENT						
Supply Current	I _{CC}	-	-	17	21	mA

Notes :

- Parameter measured at trip point at latch with V₅ = V_{REF}, V₆ = 0V
- R_T = 10KΩ, C_T = 4.7nF
- Amplifier gain define as:

$$G = \frac{\Delta V_7}{\Delta V_4}; \Delta V_4 = 0 \text{ to } 1.0 \text{ V}$$

- Current into Pin 1 guaranteed to latch circuit in shutdown state.
- Current into Pin 1 guaranteed not to latch circuit in shutdown state.
- These parameters, although guaranteed over the recommended operating conditions, are not 100% tested in production.

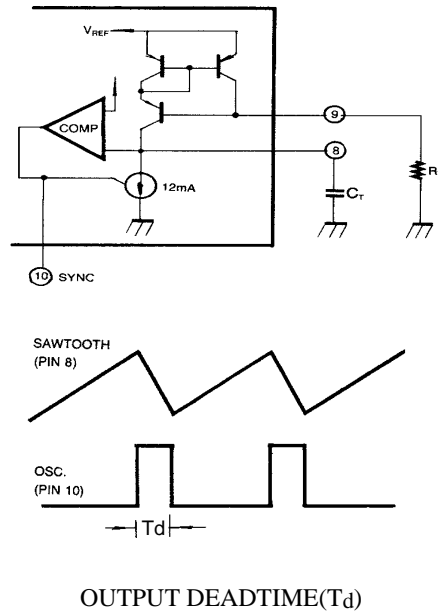

Figure 1. UC3846 Oscillator Circuit

Output deadtime is determined by the external capacitor, C_T, according to the formula: $T_d(\mu s) = 145 C_T(\mu F) \left(\frac{12}{12 - \frac{3.6}{R_T(K\Omega)}} \right)$
 For large values of R_T: T_d (us) = 145C_T (uF) Oscillator frequency is approximately

by the formula: $f_T(KHz) = \frac{2.2}{R_T(K\Omega)C_T(\mu F)}$

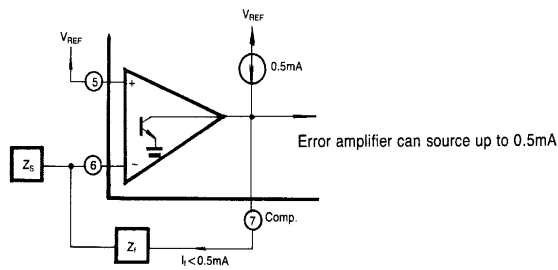

Figure 2. Error Amplifier Output Configuration

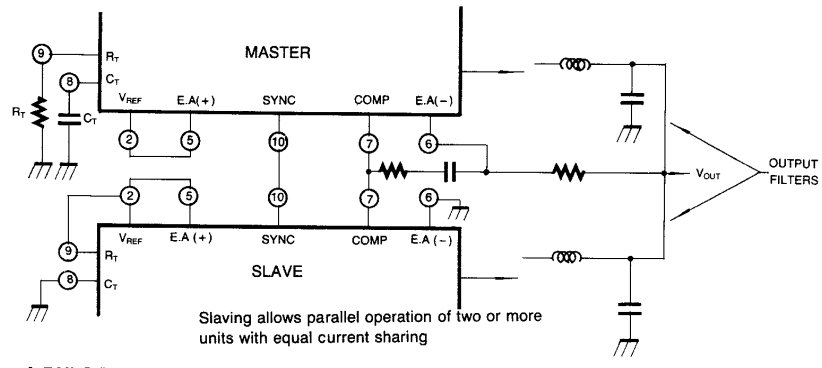

Figure 3. Parallel Operation

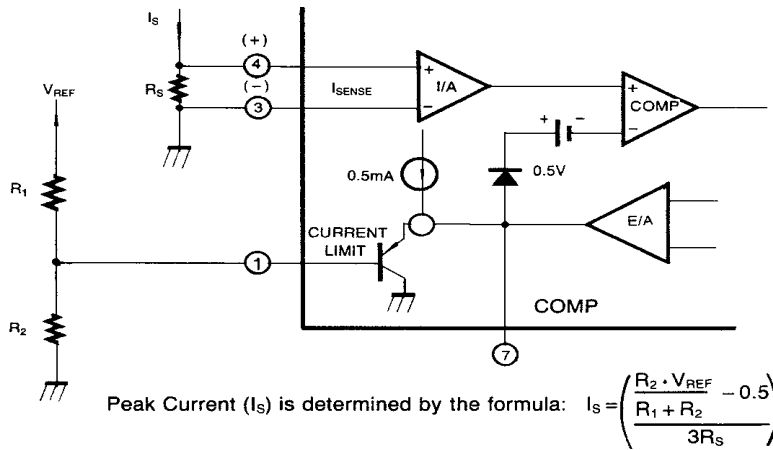

Figure 4. Pulse By Pulse Current Limiting

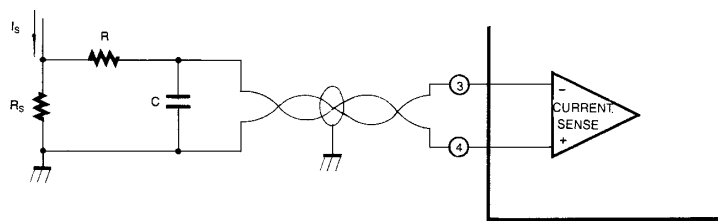

Figure 5. Current Sense Amp Connections

A small PC filter may be required in some applications to reduce switch transients
 Differential input allows remote, noise free sensing.

Mechanical Dimensions

Package

16-DIP

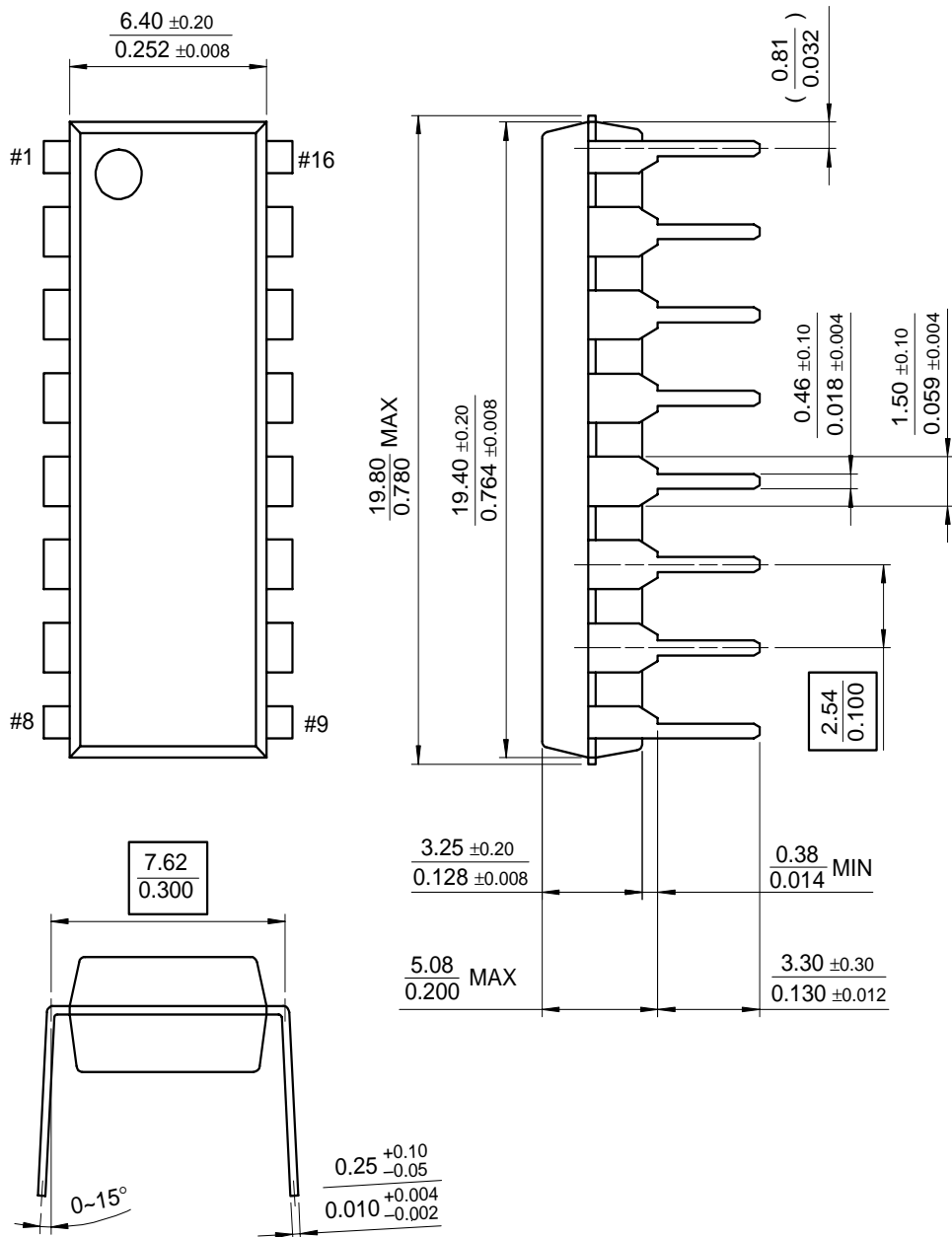

Ordering Information

Product Number	Package	Operating Temperature
UC3846N	16 DIP	0 ~ + 70°C