



**MOTOROLA**

# Octal High Voltage, High Current Darlington Transistor Arrays

The eight NPN Darlington connected transistors in this family of arrays are ideally suited for interfacing between low logic level digital circuitry (such as TTL, CMOS or PMOS/NMOS) and the higher current/voltage requirements of lamps, relays, printer hammers or other similar loads for a broad range of computer, industrial, and consumer applications. All devices feature open-collector outputs and free wheeling clamp diodes for transient suppression.

The ULN2803 is designed to be compatible with standard TTL families while the ULN2804 is optimized for 6 to 15 volt high level CMOS or PMOS.

## ULN2803 ULN2804

### OCTAL PERIPHERAL DRIVER ARRAYS

#### SEMICONDUCTOR TECHNICAL DATA

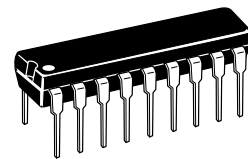

**A SUFFIX**  
PLASTIC PACKAGE  
CASE 707

**MAXIMUM RATINGS** ( $T_A = 25^\circ\text{C}$  and rating apply to any one device in the package, unless otherwise noted.)

Rating	Symbol	Value	Unit
Output Voltage	$V_O$	50	V
Input Voltage (Except ULN2801)	$V_I$	30	V
Collector Current – Continuous	$I_C$	500	mA
Base Current – Continuous	$I_B$	25	mA
Operating Ambient Temperature Range	$T_A$	0 to +70	$^\circ\text{C}$
Storage Temperature Range	$T_{\text{stg}}$	-55 to +150	$^\circ\text{C}$
Junction Temperature	$T_J$	125	$^\circ\text{C}$

$R_{\theta JA} = 55^\circ\text{C/W}$   
Do not exceed maximum current limit per driver.

### ORDERING INFORMATION

Device	Characteristics		
	Input Compatibility	$V_{CE(\text{Max})}/I_{C(\text{Max})}$	Operating Temperature Range
ULN2803A ULN2804A	TTL, 5.0 V CMOS 6 to 15 V CMOS, PMOS	50 V/500 mA	$T_A = 0$ to $+70^\circ\text{C}$

### PIN CONNECTIONS

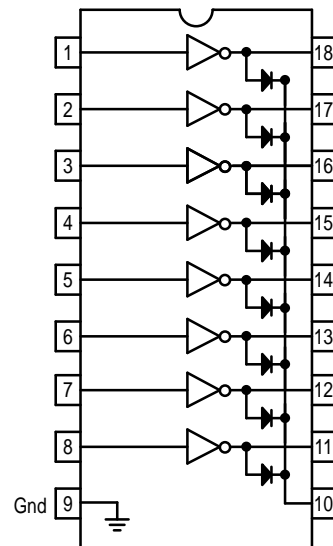

# ULN2803 ULN2804

## ELECTRICAL CHARACTERISTICS ( $T_A = 25^\circ\text{C}$ , unless otherwise noted)

Characteristic		Symbol	Min	Typ	Max	Unit
Output Leakage Current (Figure 1) ( $V_O = 50\text{ V}$ , $T_A = +70^\circ\text{C}$ ) ( $V_O = 50\text{ V}$ , $T_A = +25^\circ\text{C}$ ) ( $V_O = 50\text{ V}$ , $T_A = +70^\circ\text{C}$ , $V_I = 6.0\text{ V}$ ) ( $V_O = 50\text{ V}$ , $T_A = +70^\circ\text{C}$ , $V_I = 1.0\text{ V}$ )	All Types All Types ULN2802 ULN2804	$I_{CEX}$	– – – –	– – – –	100 50 500 500	$\mu\text{A}$
Collector–Emitter Saturation Voltage (Figure 2) ( $I_C = 350\text{ mA}$ , $I_B = 500\text{ }\mu\text{A}$ ) ( $I_C = 200\text{ mA}$ , $I_B = 350\text{ }\mu\text{A}$ ) ( $I_C = 100\text{ mA}$ , $I_B = 250\text{ }\mu\text{A}$ )	All Types All Types All Types	$V_{CE(sat)}$	– – –	1.1 0.95 0.85	1.6 1.3 1.1	V
Input Current – On Condition (Figure 4) ( $V_I = 17\text{ V}$ ) ( $V_I = 3.85\text{ V}$ ) ( $V_I = 5.0\text{ V}$ ) ( $V_I = 12\text{ V}$ )	ULN2802 ULN2803 ULN2804 ULN2804	$I_{I(on)}$	– – – –	0.82 0.93 0.35 1.0	1.25 1.35 0.5 1.45	mA
Input Voltage – On Condition (Figure 5) ( $V_{CE} = 2.0\text{ V}$ , $I_C = 300\text{ mA}$ ) ( $V_{CE} = 2.0\text{ V}$ , $I_C = 200\text{ mA}$ ) ( $V_{CE} = 2.0\text{ V}$ , $I_C = 250\text{ mA}$ ) ( $V_{CE} = 2.0\text{ V}$ , $I_C = 300\text{ mA}$ ) ( $V_{CE} = 2.0\text{ V}$ , $I_C = 125\text{ mA}$ ) ( $V_{CE} = 2.0\text{ V}$ , $I_C = 200\text{ mA}$ ) ( $V_{CE} = 2.0\text{ V}$ , $I_C = 275\text{ mA}$ ) ( $V_{CE} = 2.0\text{ V}$ , $I_C = 350\text{ mA}$ )	ULN2802 ULN2803 ULN2803 ULN2803 ULN2804 ULN2804 ULN2804 ULN2804	$V_{I(on)}$	– – – – – – – –	– – – – – – – –	13 2.4 2.7 3.0 5.0 6.0 7.0 8.0	V
Input Current – Off Condition (Figure 3) ( $I_C = 500\text{ }\mu\text{A}$ , $T_A = +70^\circ\text{C}$ )	All Types	$I_{I(off)}$	50	100	–	$\mu\text{A}$
DC Current Gain (Figure 2) ( $V_{CE} = 2.0\text{ V}$ , $I_C = 350\text{ mA}$ )	ULN2801	$h_{FE}$	1000	–	–	–
Input Capacitance		$C_I$	–	15	25	pF
Turn–On Delay Time (50% $E_I$ to 50% $E_O$ )		$t_{on}$	–	0.25	1.0	$\mu\text{s}$
Turn–Off Delay Time (50% $E_I$ to 50% $E_O$ )		$t_{off}$	–	0.25	1.0	$\mu\text{s}$
Clamp Diode Leakage Current (Figure 6) ( $V_R = 50\text{ V}$ )	$T_A = +25^\circ\text{C}$ $T_A = +70^\circ\text{C}$	$I_R$	–	–	50 100	$\mu\text{A}$
Clamp Diode Forward Voltage (Figure 7) ( $I_F = 350\text{ mA}$ )		$V_F$	–	1.5	2.0	V

# ULN2803 ULN2804

## TEST FIGURES

(See Figure Numbers in Electrical Characteristics Table)

**Figure 1.**

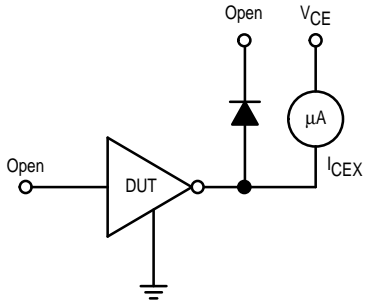

**Figure 2.**

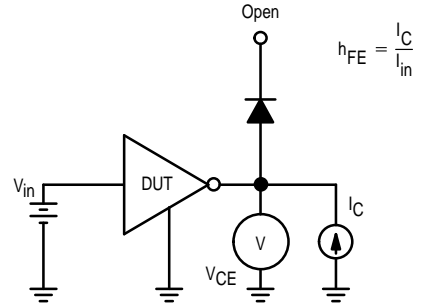

**Figure 3.**

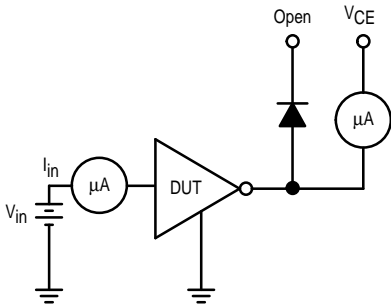

**Figure 4.**

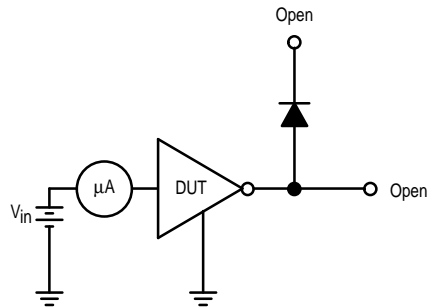

**Figure 5.**

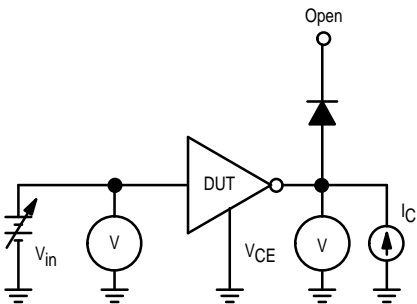

**Figure 6.**

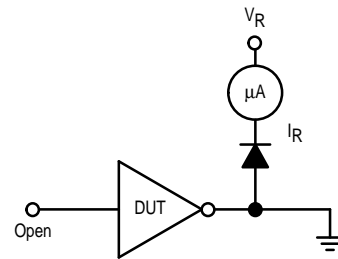

**Figure 7.**

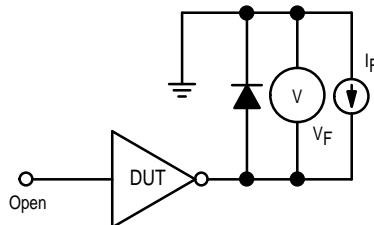

# ULN2803 ULN2804

TYPICAL CHARACTERISTIC CURVES –  $T_A = 25^\circ\text{C}$ , unless otherwise noted  
Output Characteristics

Figure 8. Output Current versus Saturation Voltage

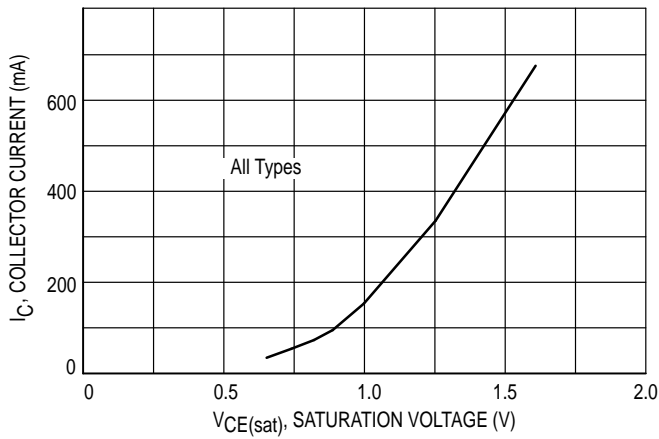
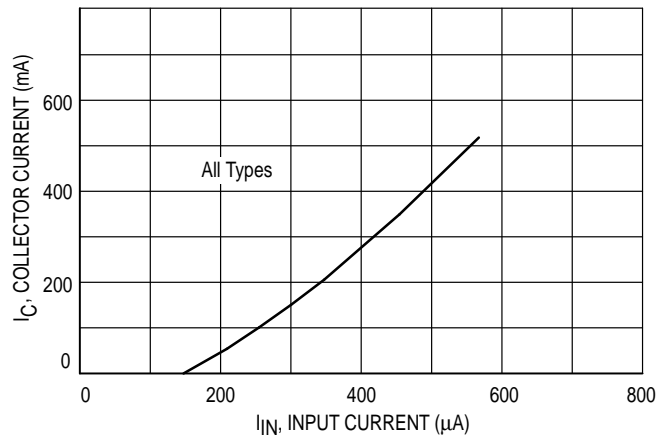

Figure 9. Output Current versus Input Current



## Input Characteristics

Figure 10. ULN2803 Input Current versus Input Voltage

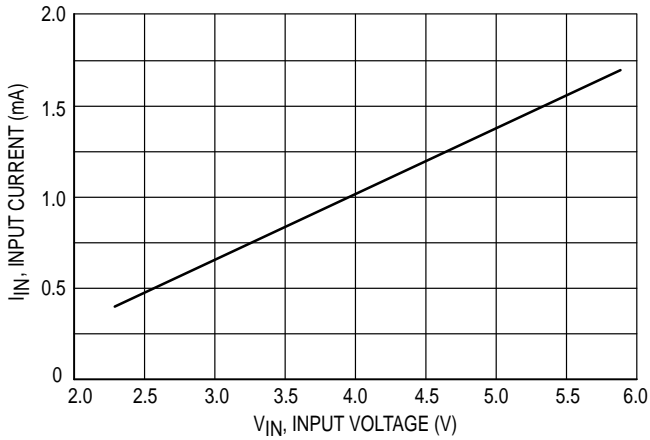

Figure 11. ULN2804 Input Current versus Input Voltage

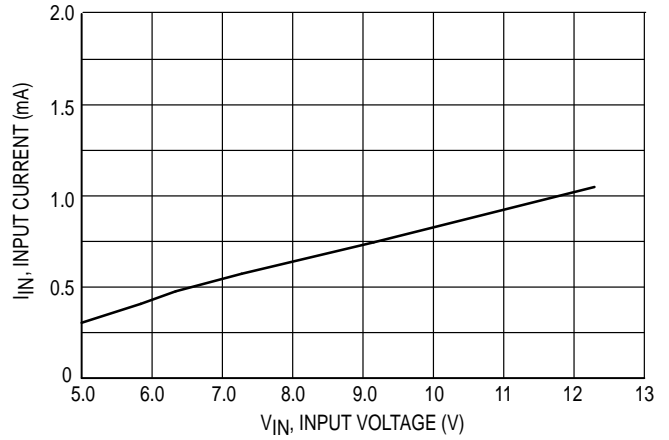
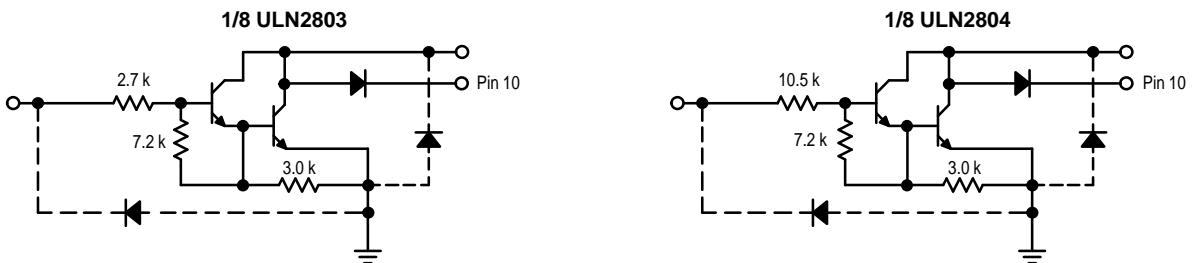

Figure 12. Representative Schematic Diagrams



# ULN2803 ULN2804

## OUTLINE DIMENSIONS

**A SUFFIX**  
**PLASTIC PACKAGE**  
**CASE 707-02**  
**ISSUE C**

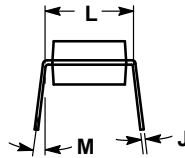
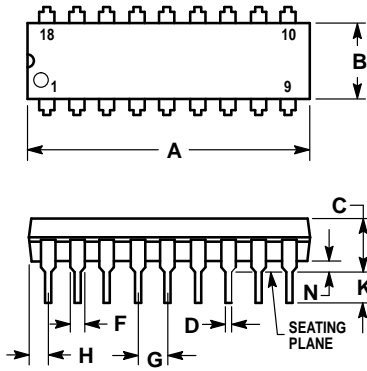

**NOTES:**

1. POSITIONAL TOLERANCE OF LEADS (D), SHALL BE WITHIN 0.25 (0.010) AT MAXIMUM MATERIAL CONDITION, IN RELATION TO SEATING PLANE AND EACH OTHER.
2. DIMENSION L TO CENTER OF LEADS WHEN FORMED PARALLEL.
3. DIMENSION B DOES NOT INCLUDE MOLD FLASH.

DIM	MILLIMETERS		INCHES	
	MIN	MAX	MIN	MAX
A	22.22	23.24	0.875	0.915
B	6.10	6.60	0.240	0.260
C	3.56	4.57	0.140	0.180
D	0.36	0.56	0.014	0.022
F	1.27	1.78	0.050	0.070
G	2.54 BSC		0.100 BSC	
H	1.02	1.52	0.040	0.060
J	0.20	0.30	0.008	0.012
K	2.92	3.43	0.115	0.135
L	7.62 BSC		0.300 BSC	
M	0°	15°	0°	15°
N	0.51	1.02	0.020	0.040