



333UGJ-1/R01

Light Emitting Diode

Description

- Size: 5mm round (T-13/4).
- Emitting color: Ultra greenish-yellow.
- Lens color: Green diffused with internal resistor.
- Lead type: Radial leads.

Main Features

- Instant light less than 100ns turn on time.
- Superior resistance to moisture.
- Low drive current, recommend forward current: $I_F = 10\text{--}20\text{mA}$.
- Cool beam, safe to touch.
- Reliable and rugged.

Absolute Maximum Rating $T_A=25^\circ\text{C}$

Parameter	Symbol	Rating	Unit	Notice
Power Dissipation	P_d	90	mW	$I_F = 20\text{mA}$
DC Forward Current	I_F	30	mA	---
Pulse Forward Current	$I_F(\text{PEAK})$	90	mA	Duty 1/10 @ 1KHz
Derating Linear From 50°C	--	0.4	mA / $^\circ\text{C}$	---
Reverse Voltage	V_R	5	V	Under 100uA
Operating Temperature Range	T_{OPR}	-25 to +70	$^\circ\text{C}$	---
Storage Temperature Range	T_{STG}	-40 to +80	$^\circ\text{C}$	Humidity should be under 50%
Lead Soldering Temperature	T_{SOL}	260 +/-5	$^\circ\text{C}$	4mm (0.157") from mold body Less then 5 Second

Part Selection Electrical / Optical Characteristics At $T_A=25^\circ\text{C}$

Characteristic	Symbol	Test Condition	Min.	Typ.	Max.	Unit.
Forward Voltage	V_F	$I_F = 20\text{mA}$	9	12	18	V
Reverse Current	I_R	$V_R = 5\text{V}$	—	—	10	μA
Luminous Intensity (Note 1)	I_v	$I_F = 20\text{mA}$	100	150	200	mcd
Peak Emission Wavelength	λ_p	$I_F = 20\text{mA}$	568	572	575	nm
Spectral Line Half Width	$\Delta\lambda$	$I_F = 20\text{mA}$	23	25	28	nm
Dominant Wavelength (Note 2)	λ_d	$I_F = 20\text{mA}$	565	570	575	nm

Note 1 : Luminous intensity is measured with a light sensor and filter combination that approximates the CIE eye-response curve.

Note 2 : The dominant wavelength (λ_d) is derived from the CIE chromaticity diagram and represents the single wavelength which defines the color of the device.

Package Dimensions

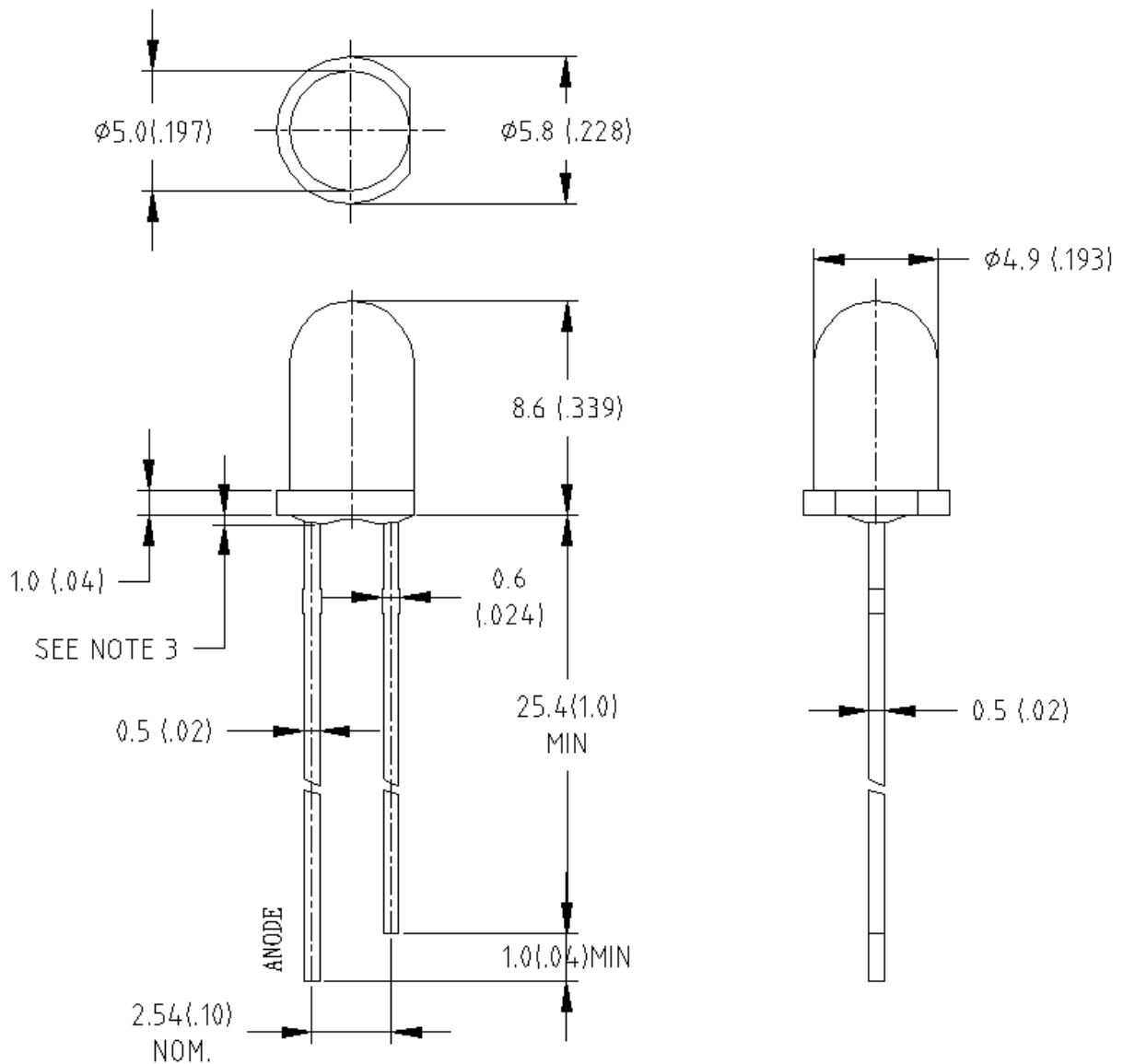

Lens Color	Light Green Diffused	Source Color	Ultra Greenish-Yellow
Chips Material	AlGaInP	Viewing Angle	60 +/- 5 deg

NOTES:

- All dimensions are in millimeters (inches).
- Tolerance is ± 0.25 mm (.010") unless otherwise noted.
- Protruded resin under flange is 1.0mm(.04") max
- Lead spacing is measured where the leads emerge from the package.
- Specifications are subject to change without notice.

Typical Electrical / Optical Characteristic Curves At 25°C Ambient Temperature

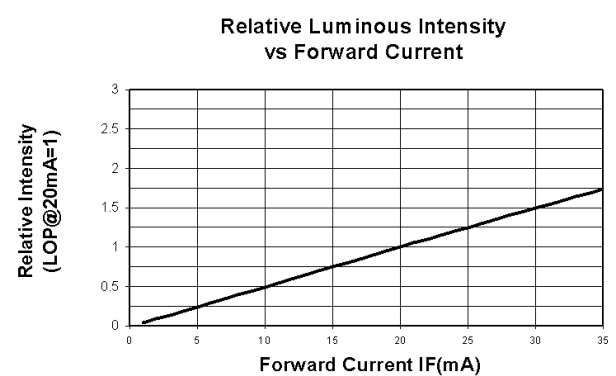
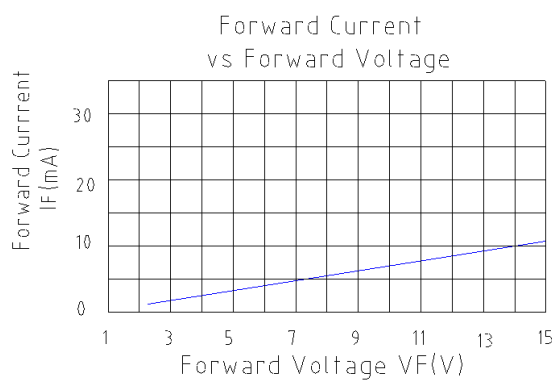
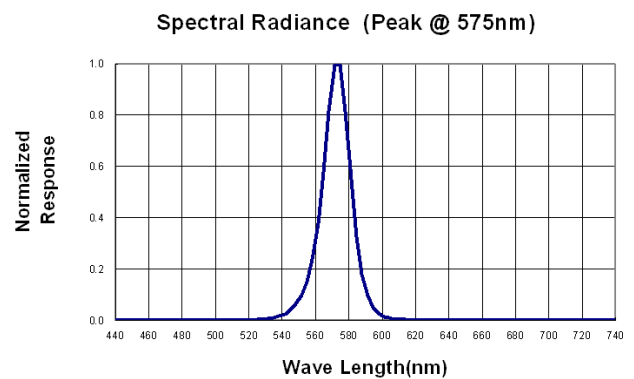
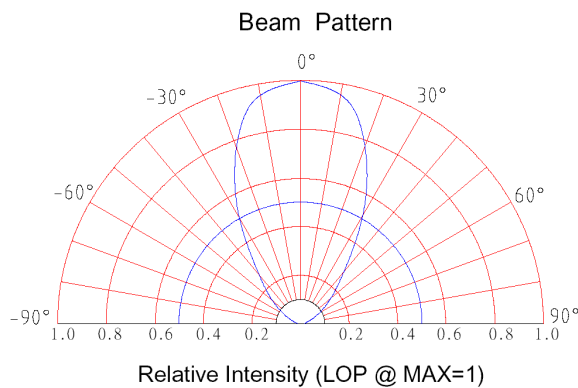

NOTE:

- $\theta_{1/2}$ is the off-axis angle at which the luminous intensity is half the axial luminous intensity.
- Clean only in isopropanol, ethanol, Freon TF (or equivalent).
- When using this product, Please observe the absolute maximum rating and the instructions for use outlined from use of the product, which does not comply with the absolute maximum rating and the instructions included in these specification sheet.
- Q.A Outgoing inspection standard:
Major Defect 0.65 A.Q.L. Minor Defect 1.5 A.Q.L
- Check at a distance of 30cm from the LED to the eye defects.
- **Lead Forming:**
If forming is required, it must be done before soldering. Form pin leads by securing under 5mm from body and bedding with radio pliers or the equivalent to avoid pressure on resin. When the LED is mounted into a P.C.board, pitch spacing should be aligned to prevent cause any stress to the resin. Any unsuitable stress applied to resin may break bonding wire in LED, which will cause failure.
- **Over-current-proof:**
Customer must apply resistor for protection; otherwise slight voltage shift will cause big current change (Burn out will happen).
- **Parallel connection:**
Customer must apply series resistor in **EACH LED** under parallel connection. Otherwise VF tolerance will cause LED array brightness uneven.
- Specifications are subject to change without notice.

