

Package Dimensions

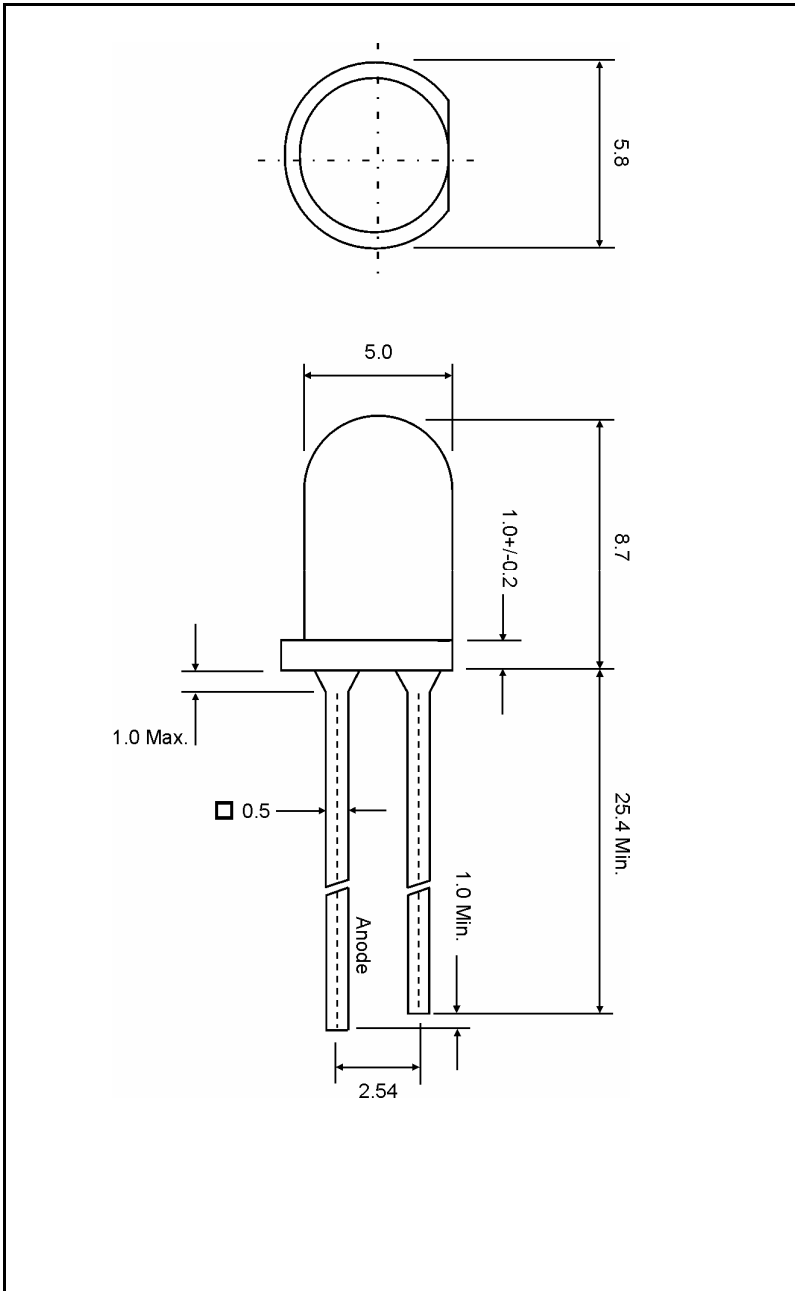

Characters

- Standard 5mm Round
- Reliable and Rugged
- Low Power Consumption
- Low Working Current

Functions

- Back-Lighting
- Light Guide

Notes

1. All Dimensions are in millimeters
2. Tolerance is +/- 0.25mm unless otherwise noted
3. Protruded resin under flange is 1.0mm max.
4. Lead measured where the leads emerge from the package
5. ESD Class (Mil-Std-883d Method 3015.7) based on Human Body Mode : 500V (Ave.)

Chip Material	Emitting Color	Lens Color
GaN	White	Water Clear



Electro-Optical Characteristics (Ta=25°C)

Parameter	Symbol	Min.	Typ.	Max.	Unit	Test Condition
Luminous Intensity	I _V	7000		10000	mcd	I _F = 20mA
Viewing Angle *	2θ ^{1/2}		20		Deg.	
Chromaticity Coordinates	X		.29			
	Y		.28			
Spectrum Radiation Bandwidth	Δλ		21		nm	
Forward Voltage	V _F	3.0	3.3	3.6	V	
Recommended Working Current	R _{IF}	10	20	25	mA	

* Viewing Angle is defined as the off-axis angle where the Luminous Intensity is 1/2 the peak intensity.

Absolute Maximum Ratings (Ta=25°C)

Parameter	Symbol	Max.	Unit
Power Dissipation	P _D	100	mW
DC Forward Current	I _F	30	mA
Peak Forward Current #	I _{PF}	120	mA
Reverse Voltage	V _R	5	V
Reverse Current	I _R	10	uA
Operation Temperature Range	T _{opr}	+ 80 ~ - 30	Deg.
Storage Temperature Range	T _{stg}	+ 100 ~ - 40	Deg.
Soldering Temperature Range *	T _{sol}	260°C for 5 Seconds	Deg.

Duty Ratio = 1/16 , Pulse width = 0.1ms

* Lead Soldering Temperature Range (1.6mm from LED Body)

Typical Electro-Optical Characteristics Curves

Forward Current VS Forward Voltage

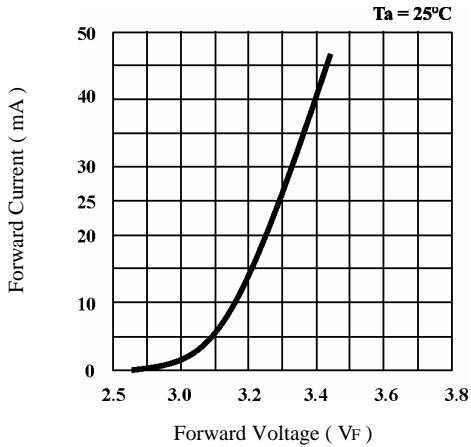

Forward Current VS Ambient Temperature

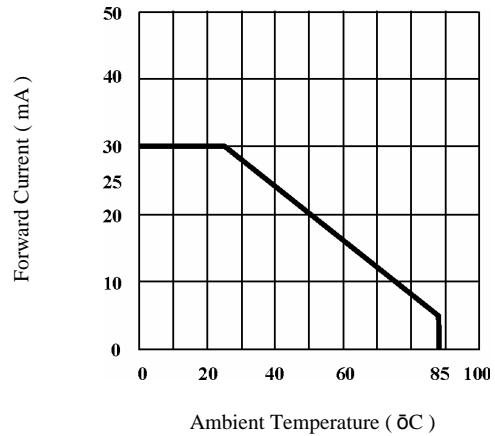

Luminous Intensity VS Ambient Temperature

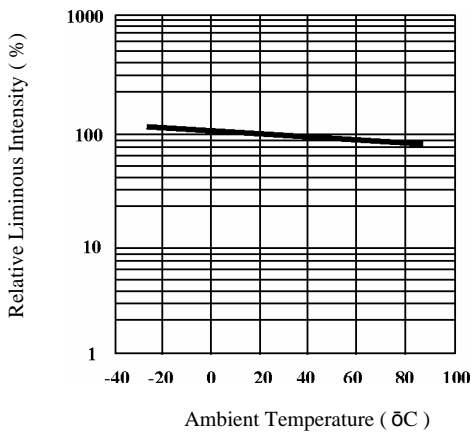

Luminous Intensity VS Forward Current

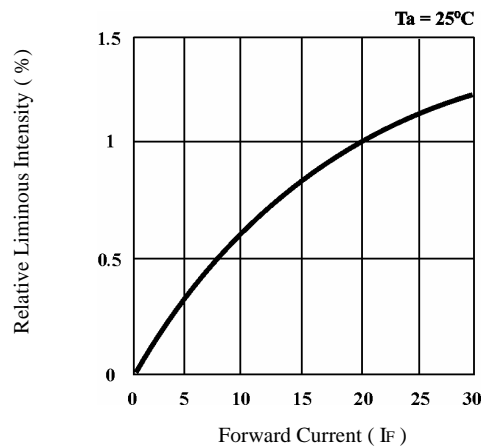

Spectrum Distribution

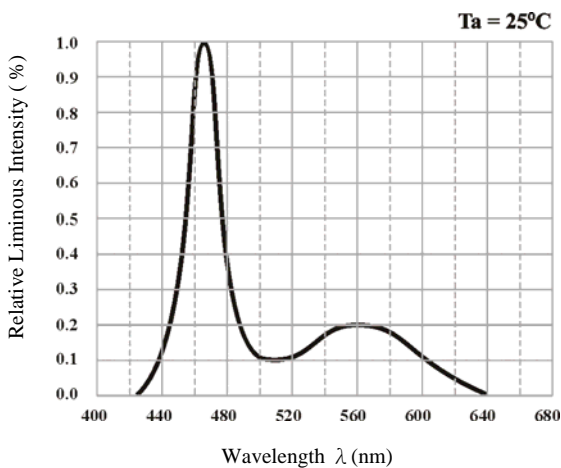

Viewing Angle Diagram

